

GXR TRUCK TRANSPORT CARRIER

NOTE: LOADING RESULTS FOR CURRENT CONFIGURATION.

NOTES:
THIS DRAWING IS FOR INFORMATION ONLY AND MAY DIFFER FROM FINAL PRODUCT.

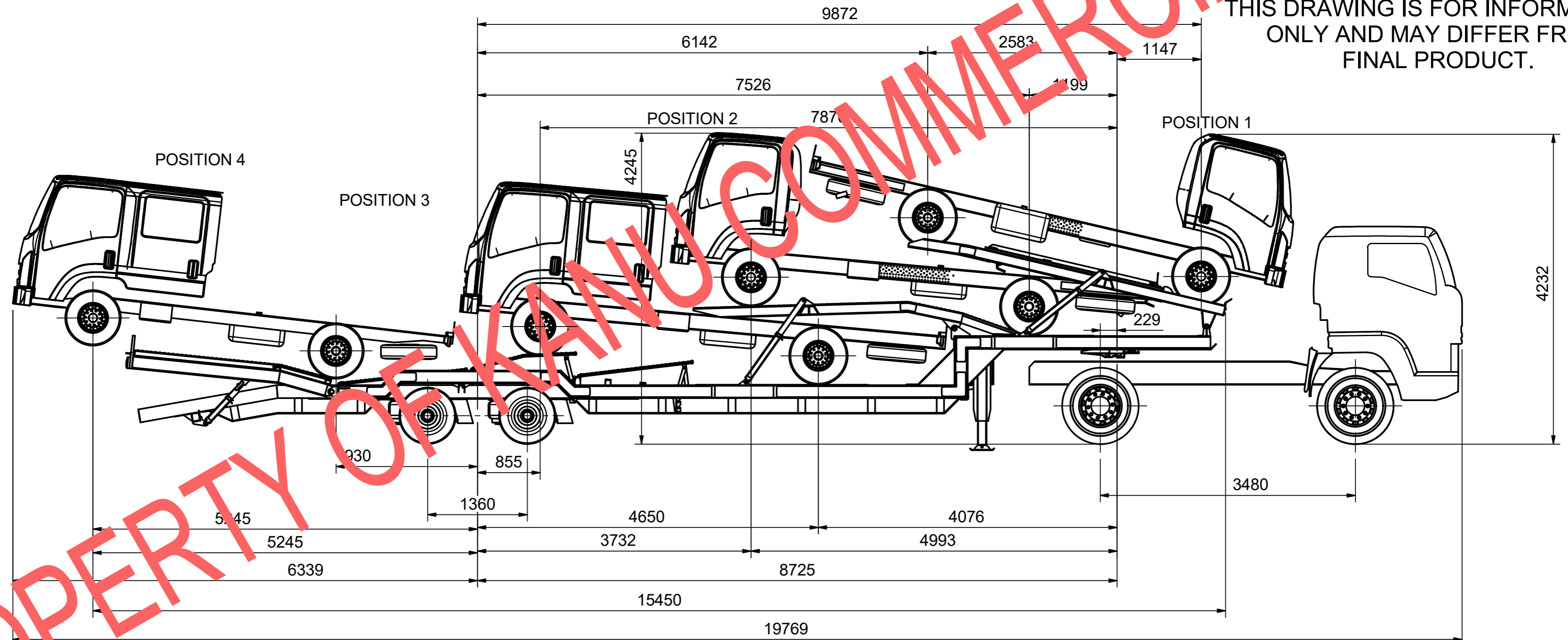

TRAILER DETAILS:
 APPROXIMATE TARE: 7311 KG
 APPROXIMATE LOADED MASS: 17 711 KG
 (CURRENT CONFIGURATION)
 AXLES FITTED: NMS/Z 6510 ECO MAXX
 AXLE CAPACITY: 6 500 KG EACH
 HYDRAULIC CYLINDERS: 30024-150 3" BORE 24" STROKE
 30030-150 3" BORE 30" STROKE
 30012-150 3" BORE 12" STROKE
 SAFETY STAYS FITTED TO CYLINDERS

TRUCKS USED FOR LOADING ILLUSTRATION:
 2X NPR 400
 TARE: 2610 KG
 FRONT AXLE TARE MASS: 1710 KG
 REAR AXLE TARE MASS: 900 KG
 1 X NPR400 CREWCAB
 TARE: 2900 KG
 FRONT AXLE TARE MASS: 1900 KG
 REAR AXLE TARE MASS: 1000 KG
 1X NMR250 CREWCAB
 TARE: 2280 KG
 FRONT AXLE TARE MASS: 1520 KG
 REAR AXLE TARE MASS: 760 KG

VEHICLE CONFIGURATION AS FOLLOWS:
 POSITION 1 FRONT: NPR 400 OR SHORTER WHEELBASE SINGLE CABS ONLY.
 POSITION 2: NPR 400 OR SHORTER WHEELBASE SINGLE CABS ONLY.
 POSITION 3: NPR 400 CREWCAB/SINGLE CAB OR SHORTER WHEELBASE.
 POSITION 4 REAR: NMR 250 STANDARD WHEELBASE OR WHEELBASE SHORTER THAN 3365MM.

TAKE NOTE: IN POSITION 4 CHEVRON BOARD AND LIGHTS NEED TO BE REMOVED.

BASE TRUCK: GXR 26-360
MASSES: GVM 16 500 KG
GCM 34 500 KG

CUSTOMER APPROVAL OF DRAWING

Drawing to be signed off and returned to Kanu Commercial. Construction will not proceed without drawing approval.

Customer: _____
 Kanu Quotation Ref: _____
 Signature: _____
 Date: ____/____/____

ORIGINAL

REMOVE ALL BURRS AND SHARP EDGES

DIMENSIONS ARE IN MILLIMETRES										GENERAL TOLERANCE (UNLESS OTHERWISE SPECIFIED)					DO NOT SCALE									
0.5 TO 6	6 TO 30	30 TO 120	120 TO 315	315 TO 1000	1000 TO 2000	2000 TO 4000	4000 TO 8000	8000 TO 12000	12000 TO 16000	±0.1	±0.2	±0.3	±0.5	±0.8	±1.5	±2	±3	±4	±5	Designed by juan.vrensburg	Checked by	Approved by	Date 2014/09/18	Date
PROJECT TRUCK TRANSPORTER										ASSEMBLY MAIN ASSEMBLY					THIS DRAWING IS THE PROPERTY OF KANU COMMERCIAL BODY CONSTRUCTION INFORMATION SHOWN MAY NOT BE DIVULGED TO ANY THIRD PARTY WITHOUT WRITTEN CONSENT.				DESCRIPTION KANU TRUCK TRANSPORT CARRIER		DRAWING No. 59001-00-01-000		Edition	Sheet 1 / 1